

Mounting instructions for hexagon swing „seta“

Item No. 51 2025 401

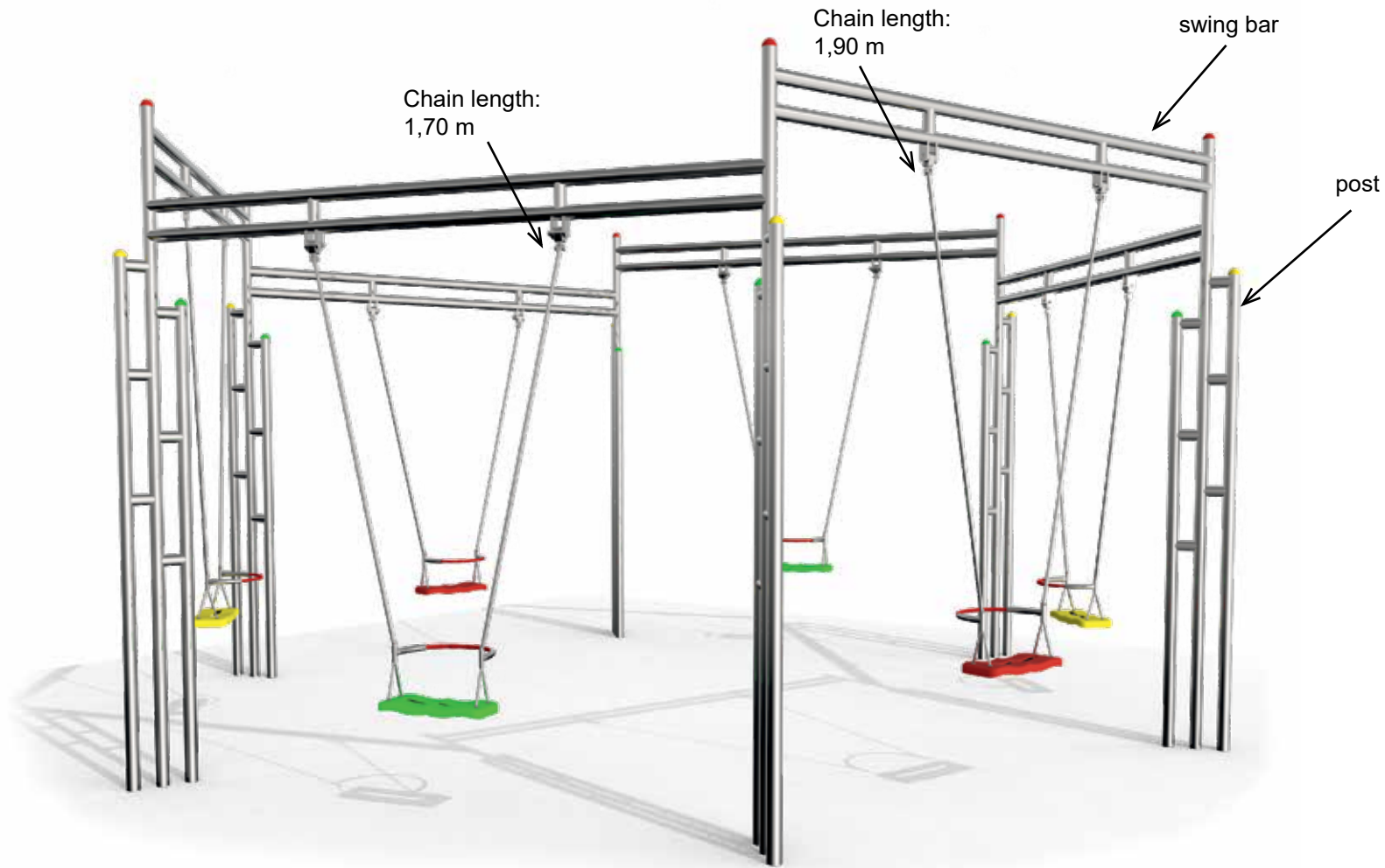
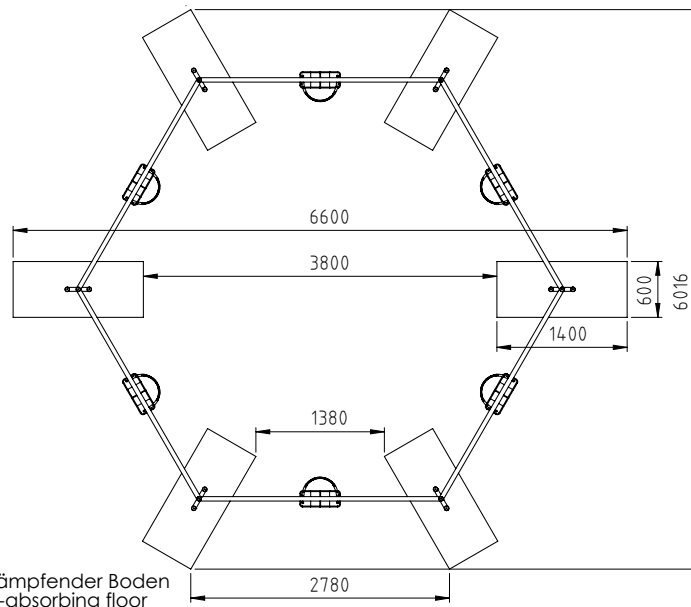
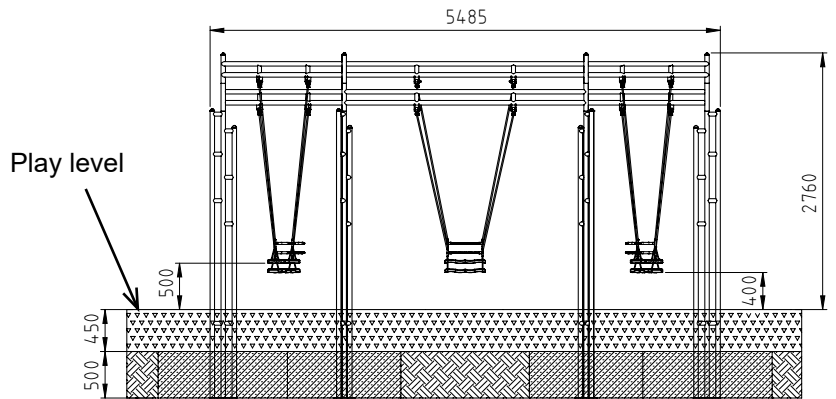

Diagram 1: Overall view of the play equipment

Mounting instructions for hexagon swing „seta“

Item No. 51 2025 401



Legende

 stoßdämpfender Boden
shock-absorbing floor

 Beton
concrete

 gewachsenes Erdreich
natural ground

Diagram 2: Foundation plan

1. Select the location of the play equipment taking into account the required minimum space (equipment space + falling space, see diagram 2 and 3).
2. The impact area of a playground equipment with an enforced movement is not allowed to overlap the impact area of other equipment. According to DIN EN 1176-1, 4.2.8.5.2 shock-absorbing floors must be made on the entire impact area of every equipment that cause forced movement.
3. Carry out excavation work for the foundations as shown in diagram 2. After excavation compress the foundation floor.
Note: The swing is installed at play level.
Pay attention to items marked „play level“ at play equipment!
4. Screw the 6 swing bars onto the 6 posts (see diagram 4). Use end caps for the tubes.
5. Set up the concrete foundations acc. to diagram 2 with central, horizontal reinforcement. Place the mounted swing into the foundations acc. to the dimensions indicated in diagram 2. Please make sure that the space between the three tubes is also filled with concrete. Compress concrete!
No warranty for damage to backwater or condensation in the tube.
Adequate drainage in the foundation is necessary.

Reinforcement plan: Concrete foundation with reinforcement

Foundation: BSt 500S

6 closed stirrups \varnothing 8mm e=25cm x-direction, crosswise

5 stirrups \varnothing 14mm e=12,5 y-direction, lengthwise

Concrete cover $h' = 3$ cm

Concrete quality class C 25/30 XC2, XF1

Mounting instructions for hexagon swing „seta“

Item No. 51 2025 401

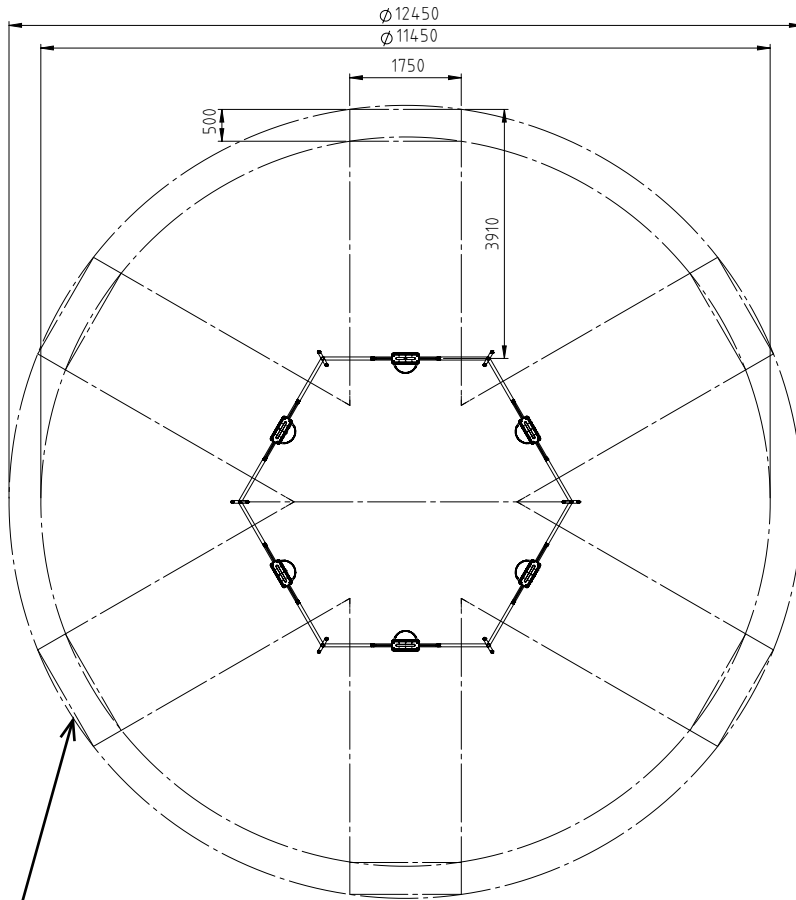

Impact area when using natural floors with a shock-absorbing effect.
When using synthetic impact protection the impact area shortens in the direction of the swing by 500 mm each. The minimum space remains preserved in its entirety.

Diagram 3: Top view

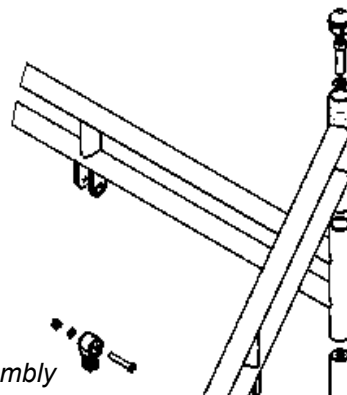

Diagram 4: Assembly

6. Align swing in vertical and horizontal direction and keep it supported until the foundations have bound off.
Note: Make sure that the supported swing is not used for playing.
7. After a setting period of 10 – 14 days, depending on weather conditions and foundation size, fill up and compress the holes between the foundation and the foundation hole with excavation.
8. Cover the entire impact area with fall protection according to the required drop height in accordance with EN 1176-1.
Critical drop height: 1500mm
Recommended surface material: sand, wood chip, gravel, synth. impact protection.
9. Screw the chains with the swing seats onto the swing suspension. Take care of the different chain lengths according to diagram 1. The jump protection has to show to the inside of the swing!
10. Do not allow children to use the equipment before the installation has been finished.

Attention: If the play equipment has been incompletely installed or partly dismantled when carrying out maintenance and repair work, this may lead to particular risks of injury for the user. For this reason, make clearly visible that the equipment shall not be used in such cases.

NOTE: Play equipment, which contain components made of stainless steel should not come with „normal“ steel parts in contact. Those steel parts may rub off and leave small steel particles in combination with moisture brown rust stains. If such corrosion occur on stainless steel parts, they are fine with an abrasive (240 grit) to remove.

Please take care when transporting and setting up the fact that the components are made of stainless steel with no „normal“ steel parts in contact.

Mounting instructions for hexagon swing „seta“

Item No. 51 2025 401



In order to preserve a good visual appearance of your stilum playground equipment over a long period one should take care of maintenance of the stainless surface even despite of their corrosion resistance.

Especially areas, which can not be reached by rainfall should be frequently cleaned from dirt and deposits due to air pollution and dirt caused by the atmosphere.

Light soiling can easily be removed by using a high pressure cleaner.

For persistent deposits use a clean cloth moistened with a special liquid cleaner (e.g. on phosphoric acid) and rinse off with clear water after a short application time. During cleaning with mild abrasive components, only wipe over stainless steel surface in polishing direction.

For heavily soiled surfaces, polishes can be used (e.g. for cleaning chrome on cars) or for greasy and oily dirt alcoholic cleaning agents and solvents (e.g. ethyl alcohol, isopropyl alcohol or acetone).

However, it should be noted that the dissolved soiling is not spread over the surface again.

Do not use any chlorid or hydrochloric containing cleaning products nor scouring powder, bleaching - or silver polish cleaner. Cleaning intervals depend on type and degree of soiling as well as on demands made on optical characteristics.

Therefore cleaning is advisable at intervals of six to twelve months – whereby in the case of strong soiling it is appropriate to clean the playground equipment at intervals of three to six months.