

DATA SHEET SEESAW SALI 4

Text for invitation to tender | Item No: 512515402



MATERIALS | SCOPE OF SUPPLY

Seesaw, pre-mounted completely

Seesaw bar:	stainless steel, V2A
Rack:	stainless steel, V2A with shaft made of stainless steel and sockets made of plastic
Handles:	stainless steel, V2A, with EPDM caoutchouc ball, 8 pieces
Seats:	EPDM caoutchouc with steel inlay, 4 pieces

TECHNICAL INFORMATION

Dimensions:

Main dimension:	3530 x 460 mm
Height:	1095 mm
Weight:	106 kg
Capacity:	acc. to normative requirements
Dimensions largest piece:	3530 x 480 x 1545 mm
Heaviest piece:	97 kg
Max. fall height:	1450 mm
Impact area:	14,00 m ²
Required safety slabs:	15,00 m ²
Required lawn grating:	18,00 m ²
Recommended surface material:	sand, wood chip, gravel, synth. impact protection

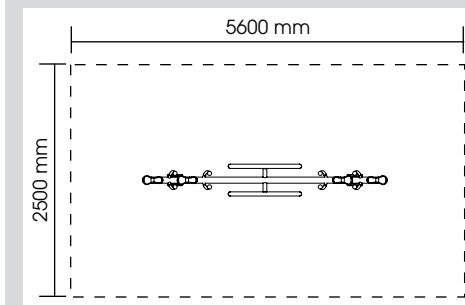
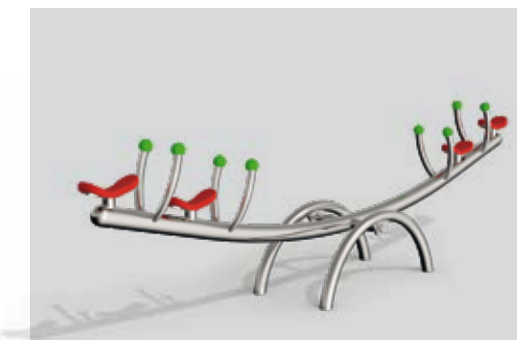

INSTALLATION

Foundations: 1 plus 2 foundations for seesaw softeners

Modified installation depth possible (special edition)

Seesaw softeners must be concreted.

Installation according to our detailed mounting instructions, see www.stilum.com

