

DATA SHEET SLIDE PHOCA

Text for invitation to tender | Item No: 51 3610 401



MATERIALS | SCOPE OF SUPPLY

Slide, pre-mounted completely

Tubular frame:	stainless steel, V2A
Slide:	stainless steel, V2A
Side cover:	HDPE plates, 2 pieces
Tube end caps	balls made of EPDM caoutchouc, 2 pieces
Slide caps:	plastic, ladder 2 pieces, slide end 2 pieces
Foundation plates:	steel, coated

TECHNICAL INFORMATION

Dimensions:

Main dimension:	2750 x 580 mm
Height:	1910 mm
Weight:	81 kg
Capacity:	acc. to normative requirements
Dimension largest piece:	2750 x 650 x 2360 mm
Heaviest piece:	81 kg

Max. fall height:	1100 mm
Impact area:	18,55 m ²
Required safety slabs:	20,75 m ²
Required lawn grating:	25,00 m ²
Recommended surface material:	sand, wood chip, gravel, synth. impact protection

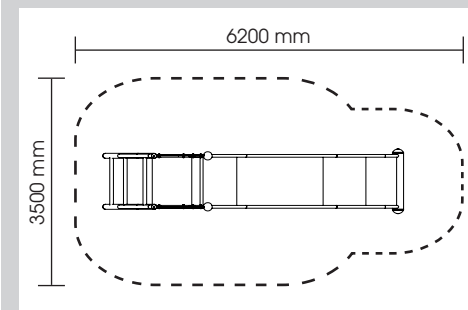
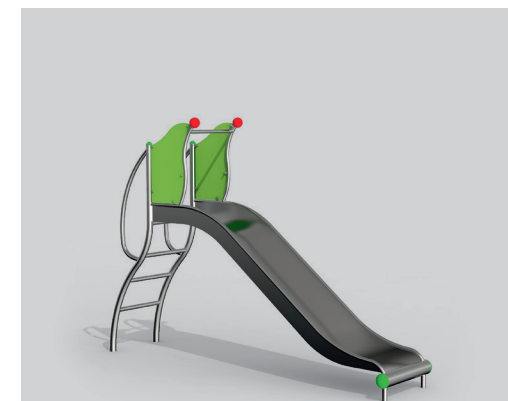

INSTALLATION

Foundations: 2
Modified installation depth possible
(special edition)

Installation according to our detailed mounting
instructions, see www.stilum.com

