

# DATA SHEET SPRINGRIDER ALTUS 1 SADDLE

Text for invitation to tender | Item No: 51 3020 402



## MATERIALS | SCOPE OF SUPPLY

Springrider, pre-mounted completely

Tubular frame:	stainless steel, V2A
Spring:	torsion spring made of steel with rubber core, 1 piece
Saddle seat:	EPDM caoutchouc with steel inlay, 1 piece
Handles:	stainless steel, V2A, with caps made of plastic, 2 pieces
Foot rest:	stainless steel, V2A, with caps made of plastic, 2 pieces
Foundation anchor:	galvanized steel

## TECHNICAL INFORMATION

Dimensions:

Main dimension:	730 x 470 mm
Height:	680 mm
Weight:	22 kg
Capacity:	acc. to normative requirements
Dimension largest piece:	730 x 500 x 1180 mm
Heaviest piece:	22 kg

Max. fall height:	500 mm
Impact area:	6,64 m <sup>2</sup>
Required safety slabs:	7,50 m <sup>2</sup>
Required lawn grating:	9,00 m <sup>2</sup>
Recommended surface material:	grass, sand, wood chip, gravel, synth. impact protection

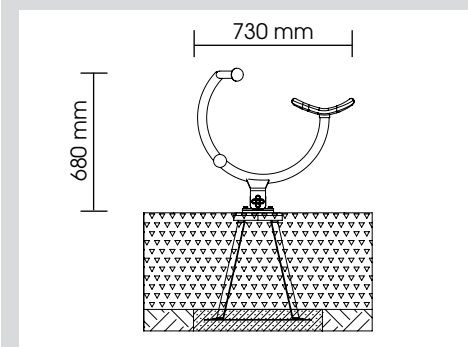
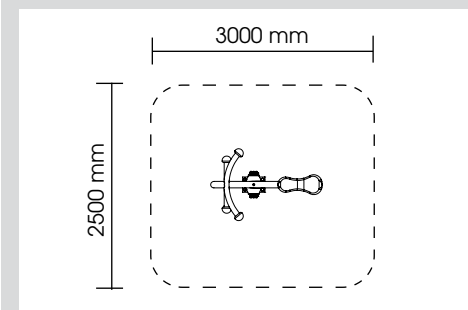
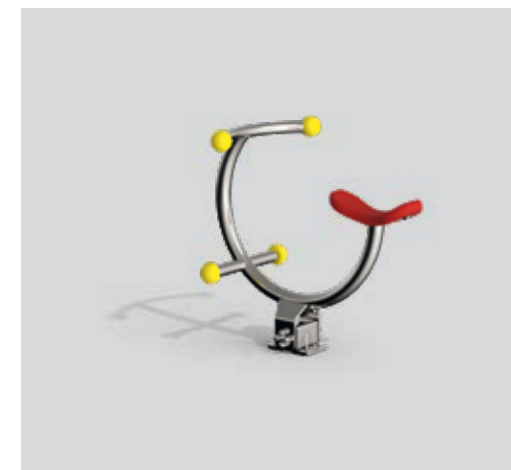

## INSTALLATION

Foundations: 1  
Modified installation depth possible (special edition)

Installation according to our detailed mounting instructions, see [www.stilum.com](http://www.stilum.com)

